

# Tips for Electrical Characterization of Carbon Nanotubes and Low Power Nanoscale Devices

**Jonathan Tucker**  
Keithley Instruments, Inc.

**T**HE potential uses for carbon nanotubes are seemingly endless, with plenty of potential applications in the semiconductor industry alone. Researchers are already incorporating carbon nanotubes into FETs for switches, memory for consumer goods, and field emission displays for the next generation of televisions. Researchers are also looking into applying carbon nanotubes in sensor applications to detect molecular particles for applications in homeland security. There is also serious work being done to use carbon nanotubes transistors for digital logic.

The semiconductor and nanotechnology community continues to be faced with challenges when working with carbon nanotubes or other low power nanoscale devices. One challenge is the difficulty of electrically characterizing extremely small circuit elements, not only in the current generation of semiconductors, but in next-generation nanoscale electronics, as well.

A second challenge is how to characterize these next generation devices when power limitation is critical. The scaling of devices and components to the nano scale forces researchers to limit the levels of electrical signals that can be applied for characterization.

Lastly, probing nanoscale devices con-

tinues to be a challenge. With standard gate dimensions of less than 90nm and space budgets shrinking continuously, the smallest probe pad dimensions required for most prober systems remain fixed at about 50 microns. This limitation is largely the result of the inaccuracy of probe movements and the size of the probe tips. This challenge is being solved with new probing tools that offer nanometer movement precision with probe tip diameters of less than 50nm and current measuring capability better than 1pA (see *Figure 1*).

This article will focus on measurement techniques that can be applied to characterizing carbon nanotubes, low power devices, and what can be done to overcome various sources of measurement error.

## Methods and Techniques

Consumers are demanding faster, more feature-rich products in ever-smaller form factors. Because the electronics must have smaller sizes, the components will also have limited power handling capability. As a result, when electrically characterizing these components, the test signals need to be kept small to prevent component breakdown or other damage. Current versus Voltage (I-V) characterization on nanoscale devices may require the measurement of very small voltages due to the necessity of applying a very small current to control power, or to reduce the Joule-heating effects. Therefore, low level voltage measurement techniques become important, not only for I-V characterization of devices, but can be extended to resistance measurements of non-conductive materials and components. For researchers

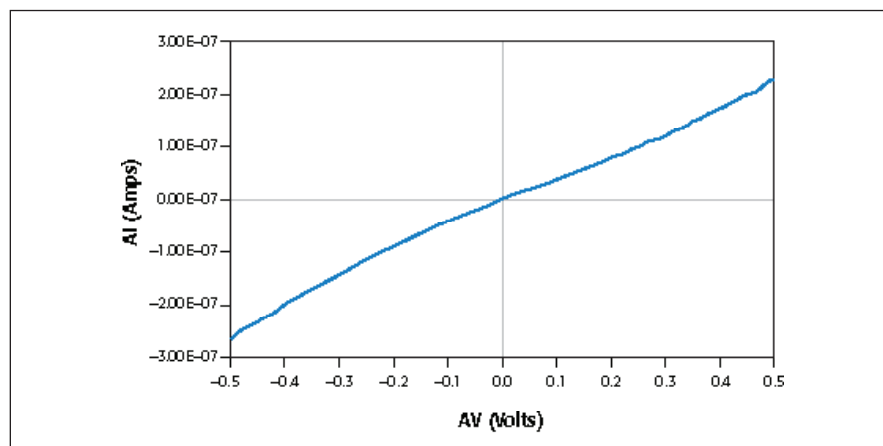

Figure 1. I-V curve on a carbon nanotube



Figure 1a. Keithley's Model 4200-SCS semiconductor characterization system.

and electronics industry test engineers, this power limitation makes characterizing the modern devices and materials, and future devices challenging.

Unlike I-V curve generation on macro- and micro-scale components and materials, measurements on carbon nanotubes and nanoscale devices require such special care and techniques. General-purpose I-V curve characterizations are often performed using a two-point electrical measurement technique. The problem with this method is that the voltage is measured not only across the device in question, but includes the voltage drop across the test leads and contacts as well. If your goal is to measure resistance of a device using a typical ohmmeter to measure resistances greater than a few ohms, this added resistance is usually not a problem. However, when measuring low resistances on conductive nanoscale materials or components, obtaining accurate results with a two-point measurement may be a problem.

If your I-V characterization or resistance measurement involves low voltage or low resistance, such as with molecular wires, semiconducting nanowires, and carbon nanotubes, a four-wire, or "Kelvin," measurement technique with a probe station is preferred and will yield more accurate results. With Kelvin measurements, a second set of probes is used for sensing. Negligible current flows in these probes due to high impedances associated with the sensing inputs; therefore, only the voltage drop across the DUT is measured (see Figure 2). As a result, your resistance measurement or I-V curve generation is more accurate. Source and measurement functions for this measurement technique are typically provided by Source-Measure Units (SMUs) (electronic instruments that source and measure DC voltages and currents).

### Typical Sources of Error

Low power electrical characterization on carbon nanotube based devices and other nanoscale components can be fraught with measurement error. Offset voltage and noise sources that can normally be ignored when measuring higher signal levels can introduce significant error into low-voltage, low current, low power measurements. We will discuss four factors that can affect measurement performance and accuracy.

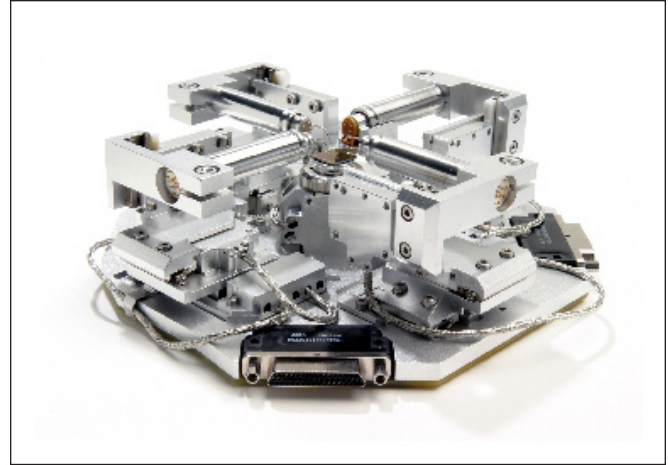

Figure 1b. Zyvex S100 Nanomanipulator.

### Offset Voltages

Ideally, when a voltmeter is connected to a relatively low-impedance circuit in which no voltages are present, it should read zero. However, a number of error sources in the circuit may show up as a non-zero voltage offset. These sources include thermoelectric EMFs, offsets generated by rectification of RFI (radio frequency interference), and offsets in the voltmeter input circuit. Steady offsets can generally be nulled out by shorting the ends of the test leads together, and then enabling the instrument's zero (relative) feature. However, canceling the offset drift may require frequent re-zeroing or using specific measurement techniques, particularly in the case of thermoelectric EMFs.

### Thermoelectric Voltages

Thermoelectric voltages, or thermoelectric EMFs, are the most common source of errors in low-voltage measurements. These voltages are generated when different parts of a circuit are at different temperatures and when conductors made of dissimilar materials are joined together. Constructing circuits using the same material for all conductors minimizes thermoelectric EMF generation.

Measurements at cryogenic temperatures pose special problems.

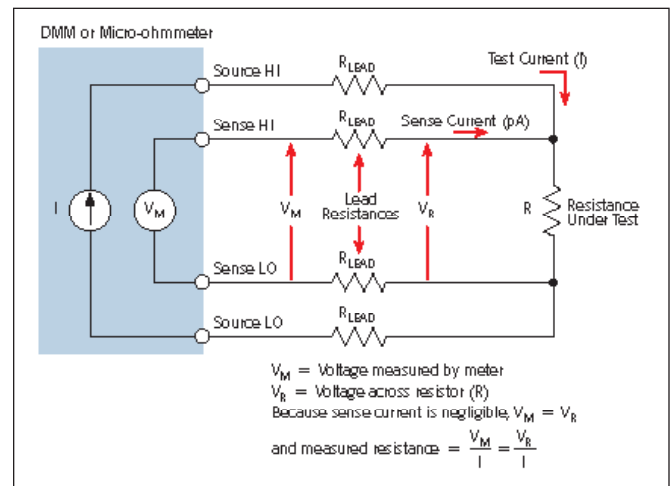

Figure 2. Four-point measurement schematic.

This is because the connections between the sample in the cryostat and the voltmeter are often made of metals with lower thermal conductivity than copper, such as iron, which introduces dissimilar metals into the circuit. In addition, because the source may be near zero Kelvin while the meter is at 300 Kelvin, there is a large temperature gradient. By matching the composition of the wires between the cryostat and the voltmeter and by keeping all dissimilar metal junction pairs at the same temperature, nanovolt measurements can be made with good accuracy.

Another approach to controlling thermoelectric voltages is to use a delta measurement technique. A constant thermoelectric voltage may be cancelled using voltage measurements made at a positive and negative test current. Alternating the test current also increases noise immunity by increasing the signal-to-noise ratio. Over the short-term, thermoelectric drift may be approximated by a linear function. The difference between consecutive voltage readings is the slope – the rate of change in thermoelectric voltage. This slope is constant, so it may be canceled by alternating the current source three times to make two-delta measurements – one at a negative-going step and one at a positive-going step. In order for the linear approximation to be valid, a current source must alternate quickly and the voltmeter must make accurate voltage measurements within a short time interval. If these conditions are met, a three-step delta technique yields an accurate voltage reading of the intended signal unimpeded by thermoelectric offsets and drifts.

### Device Heating

Small amounts of heat introduced by the measurement process itself can raise the DUT's temperature, skewing test results or even destroying the device. Device heating is a consideration when making I-V measurements on temperature-sensitive devices such as nanoscale components or materials.

The power dissipation in a device is given by  $P = I^2R$ , which means that the power dissipated in the device increases by a factor of four each time the current doubles. One way to minimize the effects of device heating is to use the lowest current possible while maintaining the desired voltage across the device being tested.

Current sources that offer pulse measurement capability can also minimize the amount of power dissipated into a DUT. Pulse measurement tools allow users to program the optimal pulse current amplitude, pulse interval, pulse width, and other pulse parameters to reduce potential device heating and control the energy applied to the device. Combined with a synchronized nanovoltmeter, the combination can synchronize the pulse and measurement—thus reducing device heating.

### Contaminated Probes

Test signal integrity when probing carbon nanotubes or nanoscale semiconductor devices depends on a high quality probe contact, which is directly related to contact resistance (*Figure 3*). Probe contact resistance has become increasingly important as signal voltages drop and contact pressures decrease.

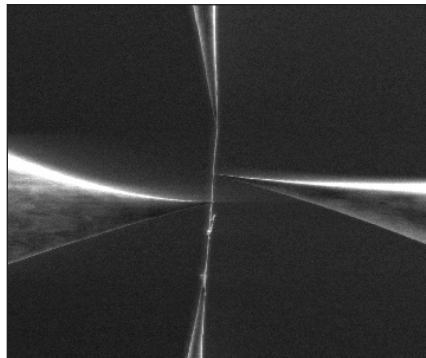

*Figure 3. SEM photo of a carbon nanotube attached to the S100 probes.*

During the course of their use, probe needles can become contaminated. Probe tip wear and contamination that builds up on the tip can cause an increase in contact resistance. The best way to enhance long-term performance of probe tips is to incorporate periodic cleaning procedures in the test protocol. While regularly scheduled cleaning removes contaminants before they cause test yield problems, this gain must be weighed against its cost. One major cost element associated with cleaning is reduced test throughput while the probe system is out of service. Another consideration is that too little cleaning adversely affects test yields.

### The Necessity for Testing Standards

As newer electronic devices are created

using carbon nanotubes or other nanoscale materials, the need for testing standards becomes more evident. Consistency in measurement technique and reporting of data is critical in order for new manufacturing processes to be consistent. Keithley Instruments worked closely with The Institute of Electrical and Electronics Engineers (IEEE) to create P1650TM-2005, the world's first measurement standard for the electrical characterization of carbon nanotubes. P1650 and future standards and recommended guidelines will permit semiconductor manufacturers and materials manufacturers of carbon nanotubes and nanoscale materials to precisely manufacture and fabricate the next generation of electronic components.

### Conclusion

This article focused on just a few of the measurement issues that the semiconductor industry and nanotechnologists must confront and overcome when designing the next generation of electronic devices. Traditional measurement techniques can still be applied, but as the dimensions of the devices shrink and power limitations are increasingly of concern, the measurement techniques must be tailored so as to achieve the results one is expecting. New measurement tools are now becoming available that address the many issues. In addition, professional organizations must continue working on developing new measurement standards so that the measurement results can be made, compared, and verified with confidence. KEITHLEY

### About the Author

Jonathan Tucker is the Lead Industry Consultant for Nanotechnology at Keithley Instruments in Cleveland, Ohio. He is currently involved with measurement solution business development for nanotechnology applications requiring electrical characterization. He is also responsible for new test & measurement application development in the Research & Education market segment. Jonathan has over 18 years of experience in Test & Measurement since receiving his Bachelors of Electrical Engineering from Cleveland State University and his MBA from Kent State University.

Specifications are subject to change without notice.  
All Keithley trademarks and trade names are the property of Keithley Instruments, Inc.  
All other trademarks and trade names are the property of their respective companies.



A G R E A T E R M E A S U R E O F C O N F I D E N C E

KEITHLEY INSTRUMENTS, INC. ■ 28775 AURORA ROAD ■ CLEVELAND, OHIO 44139-1891 ■ 440-248-0400 ■ Fax: 440-248-6168 ■ 1-888-KEITHLEY ■ www.keithley.com

**BELGIUM**

Sint-Pieters-Leeuw  
Ph: 32-2363-0040  
Fax: 32-2363-0064  
www.keithley.nl

**CHINA**

Beijing  
Ph: 8610-82255010  
Fax: 8610-82255018  
www.keithley.com.cn

**FINLAND**

Espoo  
Ph: 358 9 88171661  
Fax: 358 9 88171662  
www.keithley.com

**FRANCE**

Saint-Aubin  
Ph: 33-1-6453-2020  
Fax: 33-1-60-1-77-26  
www.keithley.fr

**GERMANY**

Germering  
Ph: 49-89-84-93-070  
Fax: 49-89-84-93-0734  
www.keithley.de

**UNITED KINGDOM**

Theale  
Ph: 44-118-929-7500  
Fax: 44-118-929-7519  
www.keithley.co.uk

**INDIA**

Bangalore  
Ph: 91-80-2212-8027  
Fax: 91-80-2212-8005  
www.keithley.com

**ITALY**

Milano  
Ph: 39-02-55 38 421  
Fax: 39-02-55 38 42 28  
www.keithley.it

**JAPAN**

Tokyo  
Ph: 81-3-5733-7555  
Fax: 81-3-5733-7556  
www.keithley.jp

**KOREA**

Seoul  
Ph: 82-2-574-7778  
Fax: 82-2-574-7838  
www.keithley.co.kr

**MALAYSIA**

Kuala Lumpur  
Ph: 60-3-4041-0899  
Fax: 60-3-4042-0899  
www.keithley.com

**NETHERLANDS**

Gorinchem  
Ph: 31-1-836-35333  
Fax: 31-1-836-30821  
www.keithley.nl

**SINGAPORE**

Singapore  
Ph: 65-6747-9077  
Fax: 65-6747-2991  
www.keithley.com.sg

**SWEDEN**

Solna  
Ph: 46-8-509-04-600  
Fax: 46-8-655-26-10  
www.keithley.com

**TAIWAN**

Hsinchu  
Ph: 886-3-572-9077  
Fax: 886-3-572-9031  
www.keithley.com.tw